

FEATURES

- High intensity and reliability.
- High quality and low cost.
- Choice of colors: Red/Orange/Green/Blue, etc
- Low power requirement.
- I. C. compatible.
- Easy assembly.

DESCRIPTION

The WCN1-XX31XX-XXXU and WCN1-XX31XX-XXX series are 0.31 inch (8.0mm) height single digit displays.

SH. Red displays have black face or gray face and Milky segment or red segment.

Orange displays have black face or gray face and Milky segment or red segment.

Yellow Green displays have black face or gray face and Milky segment or green segment.

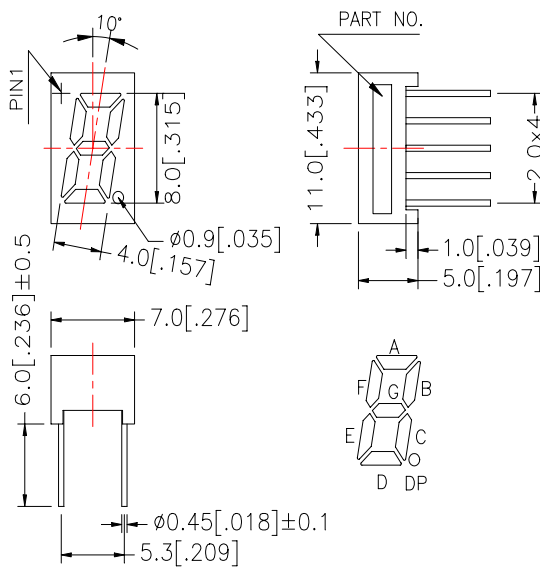
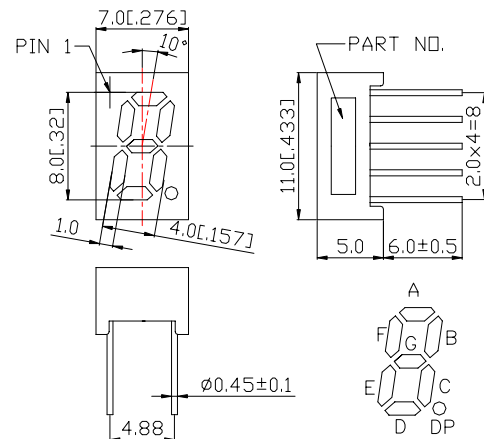
PACKAGE DIMENSIONS
A. WCN1-XX31XX-A11U/C11U

B. WCN1-XX31XX-A11/C11

NOTES: All dimensions are in millimeters (inches) tolerance are $\pm 0.25\text{mm}$ (0.010) unless otherwise noted.

INTERNAL CIRCUIT DIAGRAM

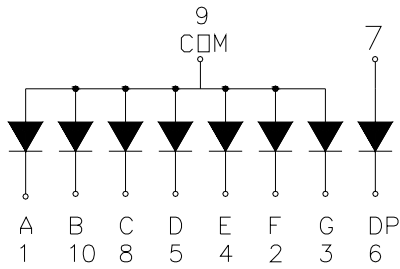
A. WCN1-XX31XX-A1XU/A11



B. WCN1-XX31XX-C1XU/C11

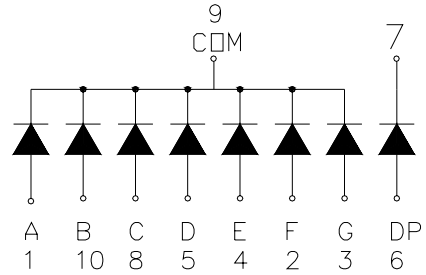

ABSOLUTE MAXIMUM RATINGS AT $T_a=25^\circ\text{C}$

PARAMETER	SH.RED	ORANGE	Yellow GREEN	UNIT
Power Dissipation Per Segment	50	65	65	mW
Peak Forward Current Per Segment (1/10 duty cycle 0.1ms pulse width)	100	100	100	mA
Continuous Forward Current Per Segment	25	25	25	mA
Derating Linear From 25°C Per Segment	0.30	0.20	0.33	mA/ $^\circ\text{C}$
Reverse Voltage Per Segment	5	5	5	V
Operating Temperature Range	-35 $^\circ\text{C}$ to + 85 $^\circ\text{C}$			
Storage Temperature Range	-35 $^\circ\text{C}$ to + 85 $^\circ\text{C}$			
Solder Temperature 1/16 inch below seating plane for 3 seconds at 260 $^\circ\text{C}$				

ELECTRICAL/OPTICAL CHARACTERISTICS AT $T_a=25^\circ\text{C}$

WCN1-0031SR-A11U/C11U ; WCN1-0031SR-A11/C11

PARAMETER	SYMBOL	MIN.	TYP.	MAX.	UNIT	TEST CONDITION
Luminous Intensity Per Segment	I_v	2.0	3.0	—	mcd	$I_F=10\text{mA}$
Dominant Wavelength	λ_D	—	643	—	nm	$I_F=20\text{mA}$
Peak Emission Wavelength	λ_P	—	660	—	nm	$I_F=20\text{mA}$
Spectral Line Half-Width	$\Delta\lambda$	—	20	—	nm	$I_F=20\text{mA}$
Forward Voltage Per Segment	V_F	—	1.8	2.0	V	$I_F=20\text{mA}$
Reverse Current Per Segment	I_R	—	—	100	μA	$V_R=5\text{V}$
Luminous Intensity Matching Ratio (Segment to Segment)	I_{v-m}			2:1		$I_F=10\text{mA}$

ELECTRICAL/OPTICAL CHARACTERISTICS AT T_a=25°C**WCN1-0031HO-A11U/C11U ; WCN1-0031HO-A11/C11**

PARAMETER	SYMBOL	MIN.	TYP.	MAX.	UNIT	TEST CONDITION
Luminous Intensity Per Segment	I _V	0.8	1.2	—	mcd	I _F =10mA
Dominant Wavelength	λ _D	—	622	—	nm	I _F =20mA
Peak Emission Wavelength	λ _P	—	632	—	nm	I _F =20mA
Spectral Line Half-Width	Δλ	—	35	—	nm	I _F =20mA
Forward Voltage Per Segment	V _F	—	2.05	2.60	V	I _F =20mA
Reverse Current Per Segment	I _R	—	—	100	μA	V _R =5V
Luminous Intensity Matching Ratio (Segment to Segment)	I _{V-m}			2:1		I _F =10mA

WCN1-0031GU-A11U/C11U ; WCN1-0031GU-A11/C11

PARAMETER	SYMBOL	MIN.	TYP.	MAX.	UNIT	TEST CONDITION
Luminous Intensity Per Segment	I _V	1.0	2.0	—	mcd	I _F =10mA
Dominant Wavelength	λ _D	—	573	—	nm	I _F =20mA
Peak Emission Wavelength	λ _P	—	568	—	nm	I _F =20mA
Spectral Line Half-Width	Δλ	—	30	—	nm	I _F =20mA
Forward Voltage Per Segment	V _F	1.80	2.25	2.60	V	I _F =20mA
Reverse Current Per Segment	I _R	—	—	100	μA	V _R =5V
Luminous Intensity Matching Ratio (Segment to Segment)	I _{V-m}			2:1		I _F =10mA